

Measuring Mass

Reminder – Goggles must be worn at all times in the lab.

PRE-LAB DISCUSSION:

For laboratory work in chemistry, three basic types of measurement using the balance should be mastered. These are: measuring mass directly, “measuring out” a specific mass of a substance, and determining mass by difference. These three types of measurement and the techniques for making them are briefly described in the following paragraphs.

Measuring Mass Directly. Direct measurement is used to determine the mass of a beaker or flask, or similar object. This is the simplest type of measurement made with the balance. In a direct measurement, the object whose mass is to be measured is placed on the balance pan and the riders are moved into positions along the beams until the pointer is balanced at the zero point. The mass of the object is read directly from the positions of the riders on the beams.

“Measuring Out” a Predetermined Mass. This technique is often used to obtain a desired mass of a solid chemical, such as table salt, that exists in a granular or crystalline state. NEVER PLACE CHEMICALS DIRECTLY ON THE PAN. A piece of paper or a container of some kind, such as a watch glass, should be placed on the pan to hold the substance. The pre-set mass must be equal to the container (called the “tare”) PLUS the mass of substance to be measured. Liquids may also be weighed in this way, using beakers or graduated cylinders.

Determining Mass by Difference. As the name suggests this technique involves subtraction. In this case, it is necessary to subtract the mass of the empty container from the combined mass of the container and the substance.

PURPOSE:

The purpose of this lab is to practice the various techniques of measuring masses using the laboratory balance.

PROCEDURE:

I. Using the Balance.

The proper use of the balance is described in the following steps:

A. When transporting a balance, be careful to hold it steady in order to protect the beams and “knife edge.” NEVER BANG ON THE BEAMS. Check to see that the balance is properly “zeroed.” To do this, be sure the pan is clean and empty, and set the riders to zero. The pointer should swing an equal distance on each side of the zero point. If it does not, use the adjustment screw to obtain an equal swing of the pointer.

B. NEVER PLACE CHEMICALS DIRECTLY ON THE PAN. Samples to be measured should be placed on a piece of paper or in a container. Never place hot objects on the balance. Allow samples to cool before measuring.

C. Once the object whose mass is to be determined is on the pan, move the rider of greatest mass along its beam, one notch at a time, until it causes the pointer to drop. Then move the rider BACK one notch. Repeat this procedure with each succeeding rider of smaller mass. Make sure each rider is securely in its notch. The front beam, which is marked off in the smallest increments, is not notched. Slide the rider on this beam until the pointer swings an equal distance on each side of the zero on the scale.

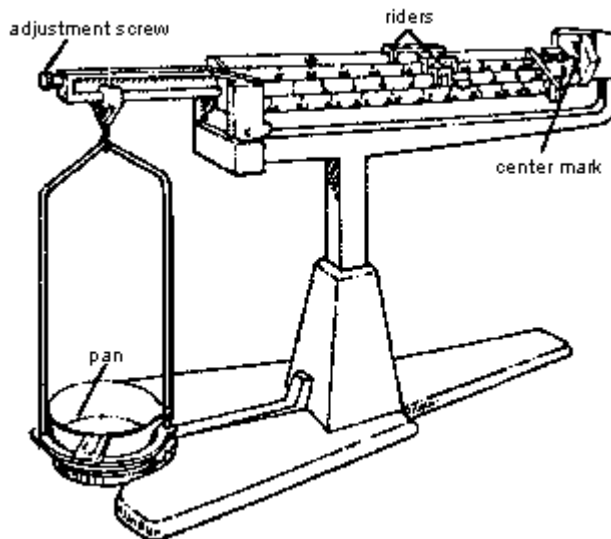

D. When the pointer is zeroed, sum up the masses shown on the beams. Remember, significant figures are all figures known with certainty AND ONE GUESS. With our scales, we can read down to the hundredths place for CERTAIN and we can GUESS the thousandths place. Therefore, in this class, ALWAYS record all masses to THREE PLACES PAST THE DECIMAL POINT.

Example: 4.125 grams. The "5" would be a guess to indicate that the pointer was half-way between two markings.

See the following examples. Remembering to GUESS the thousandths place, the first scale reads 24.560 grams and the second figure reads 107.060 grams.

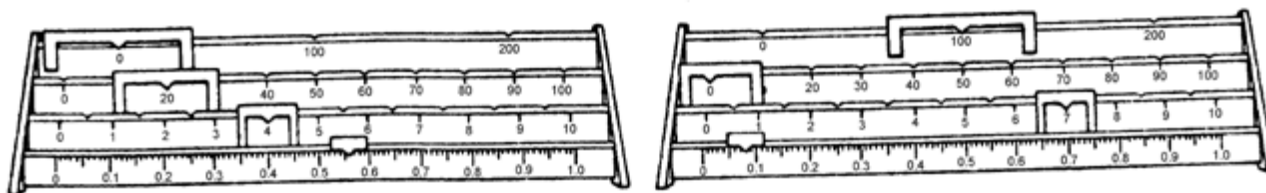

II. Measuring Mass Directly.

A. Check your balance to make sure your pointer is properly "zeroed."

B. Place a penny on the pan. Move the riders until the pointer is balanced (zeroed). Record the mass of the penny.

C. Repeat step 2 for the objects listed below. Record the mass of each object.

- 1) a nickel
- 2) a watch glass
- 3) a 10 mL graduated cylinder

III. Measuring Out A Predetermined Mass.

A. Place your clean watch glass on the balance. Move the rider on the beams until the balance is zeroed. Record this reading (this should be the same reading as in the previous section).

B. Now, move the riders until they read exactly 1.000 grams MORE than the reading you obtained for the watch glass. Record this setting.

C. Using the sodium chloride (NaCl) provided by your instructor, and your spatula, add NaCl to the watch glass until the pointer is balanced. This is the method you would use if your instructor directed you to "weigh out 1.000 grams of NaCl."

D. Discard the NaCl in the waste bin when you are finished. NEVER RETURN USED CHEMICALS TO A STOCK BOTTLE DUE TO THE RISK OF CONTAMINATION.

IV. Determining Mass By Difference

Part 1 - Solids

A. Place your clean watch glass on the balance, moving the riders to agree with your recorded mass for the watch glass.

B. Using your spatula, place one heaping scoop of sodium chloride (NaCl) on the watch glass. Measure and record the combined mass of the watch glass and the NaCl.

C. Add a second heaping spatula scoop of NaCl to the watch glass. Measure and record the combined mass of the watch glass and the 2 scoops of NaCl.

D. Add a third heaping spatula scoop of NaCl to the watch glass. Measure and record the combined mass of the watch glass and salt. Discard the salt in the waste bin.

Part 2 - Liquids

E. Measure and record the mass of your 10 mL graduated cylinder (you may use the result obtained previously).

F. Fill your graduated cylinder with EXACTLY 10.00 ml of water.

G. Measure and record the combined mass of the cylinder and water.

RESULTS:Data

Do NOT write here. Record all data on your lab paper! Remember to record all masses to three places past the decimal.

Part II

Object	Mass in grams
Penny	XXXX g
Nickel	XXXX g
Watch glass	XXXX g
10 mL Graduated cylinder	XXXX g

Part III

Watch Glass	XXXX g
Sodium Chloride	XXXX g
Total	XXXX g

Part IV

Watch glass	XXXX g
Watch glass + one scoop NaCl	XXXX g
Watch glass + two scoops NaCl	XXXX g
Watch glass + three scoops NaCl	XXXX g
10 mL Graduated cylinder	XXXX g
Cylinder + 10 mL water	XXXX g

Calculations (SHOW YOUR WORK! No work = No credit)

1. Calculate the mass of the each scoop of NaCl from Part IV. Show your work.
2. Calculate the AVERAGE mass of a scoop of NaCl from Part IV. Show your work.
3. Calculate the mass of 10.00 ml of water.
4. Calculate the mass of 1.00 ml of water from your answer to the previous calculation.